

Order Information:

Part No.	Wire (AWG)	Color
1822 1104 412	12	Red
1822 1104 414	14	
1822 1104 416	16	
1822 1104 418	18	
1822 1104 420	20	

SPECIFICATIONS:

Suitable Rated Current : 30A Max.
 Dielectric Strength for 60 Seconds : AC 1500V Min
 Insertion & Extraction Force : 1kg. Min
 Contact Resistance at 1A DC : 5mΩ Max.
 Insulation Resistance at 500V DC : 100MΩ Min.
 Voltage Drop : 20mV Max.
 Temperature Rise : 50°C Max.
 Wire : 6 inch ; UL 1015
 Type : Water Resistant Type
 Molded Parts : PVC
 Terminals : Phosphor Bronze
 * Other wire size or length available on special order

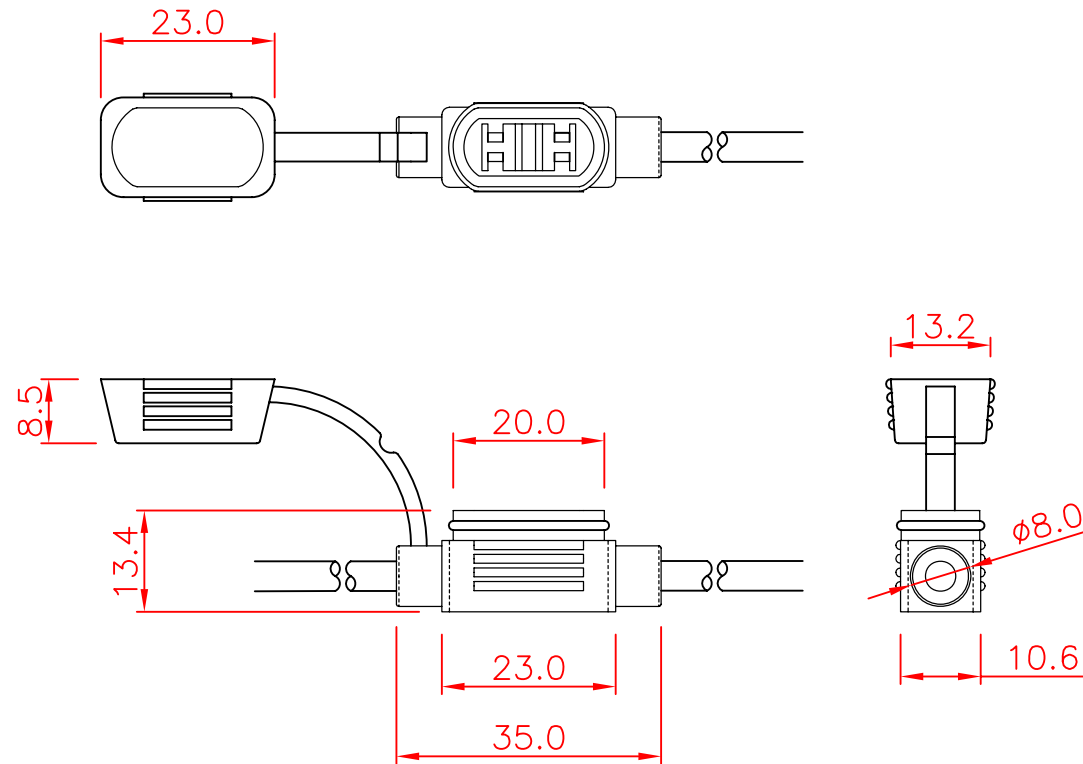

Tolerances : Unless Otherwise Specified		
Dimension	Critical To Function	General
< 1	+/- 0.02	+/- 0.03
1 ~ 8	+/- 0.1	+/- 0.2
8 ~ 24.995	+/- 0.15	+/- 0.25
25 ~ 99.99	+/- 0.2	+/- 0.3
Angles	+/- 1°	+/- 5°

Rev	EN	Description	Dwg	Ckd	Appd	Date
B	93092401	Modify the tolerance	Kao	Chyi	Ku	2004/9/24

Material		Drawn	GLORYTECH TECHNOLOGY CO., LTD.			
Finish		Check	Title:		A4	B
		Engr	In-Line Fuse Holder		GTQD-HLD-1822-1104	B
		Appd	Scale: 1:1			
Unless Otherwise Specified Dimensions are mm (inch) Tolerances: .x = 1.0 (.04) .xx = 0.5 (.02) .xxx = 0.25 (.010)			Dwg Size	Sht 1 of 1	Rev	
Model File Name : In-Line Fuse Holder for Low Profile Mini Blade Type Fuses						
Drawing File Name : GTQD-HLD-1822-1104						
Part Number : 1822 1104 4xx					Date:	2012/2/8