

Specifications :

Body : PET
 Cover : PET, Red
 Terminal : Copper Alloy, Tin Plated
 Standard : UL248 Special Purpose Fuse
 Approval File No. E498356-JFHR2/8
 Interruption Ratings : AC250V 400A /
 DC80V1000A

Filled with sand

Order Information:

Part Number	Ampere Rating	Body Color
1541 2200 2250	20A	Yellow
1541 2250 2250	25A	Gray
1541 2300 2250	30A	Green
1541 2350 2250	35A	Brown
1541 2400 2250	40A	Orange
1541 2500 2250	50A	Red
1541 2600 2250	60A	Blue

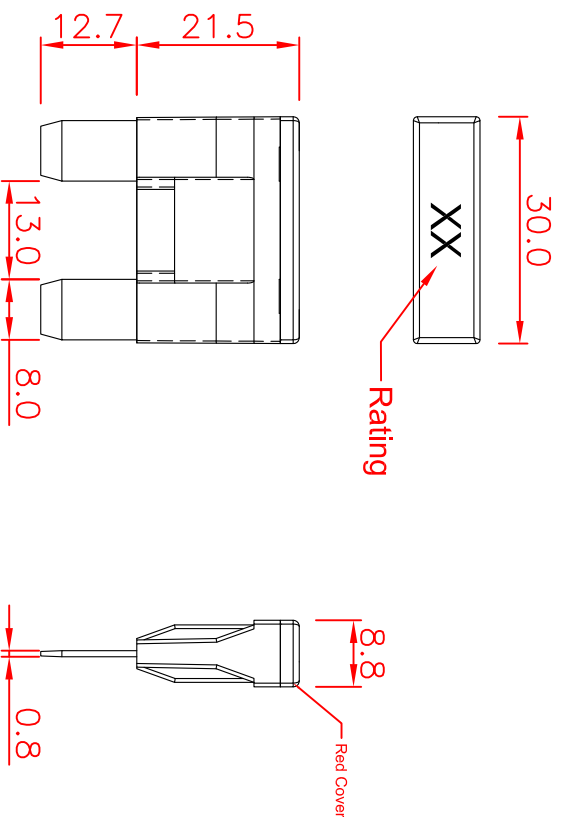

Opening Time / Pre-arcing Time:

In	135%		200%		350%		600%	
	Min.	Max.	Min.	Max.	Min.	Max.	Min.	Max.
20 ~ 60A	> 100h	30s	3600s	1s	60s	0.2s	7s	1s

GLORYTECH TECHNOLOGY CO., LTD.

Title: AC250V Max Blade Type Automotive Fuse

Type A4 GTQD-FUS-1541-250V

Scale: 1:1 Dwg Size Sht 1 of 1 Rev

Model File Name : AC250V Max Blade Type Automotive Fuse

Drawing File Name : GTQD-FUS-1541-250V

Part Number : 1541 xxxx 2250 Date: 2019/1/18

Tolerances : Unless Otherwise Specified		
Dimension	Critical To Function	General
< 1	+/- 0.02	+/- 0.03
1 ~ 8	+/- 0.1	+/- 0.2
8 ~ 24.995	+/- 0.15	+/- 0.25
25 ~ 99.99	+/- 0.2	+/- 0.3
Angles	+/- 1°	+/- 5°

Rev	EN	Description	Dwg	Ckd	Appd	Date
B	93092401	Modify the tolerance	Kao	Chyi	Ku	2004/9/24
C	108011801	UL認證通過改版	Kao	Chyi	Ku	2019/1/18